

**MITSUBISHI ELECTRIC CORPORATION**  
**PUBLIC RELATIONS DIVISION**  
7-3, Marunouchi 2-chome, Chiyoda-ku, Tokyo, 100-8310 Japan

**FOR IMMEDIATE RELEASE**

**No. 3299**

*Customer Inquiries*

*Media Inquiries*

Advanced Technology R&D Center  
Mitsubishi Electric Corporation  
[www.MitsubishiElectric.com/ssl/contact/company/rd/form.html](http://www.MitsubishiElectric.com/ssl/contact/company/rd/form.html)  
[www.MitsubishiElectric.com/company/rd/](http://www.MitsubishiElectric.com/company/rd/)

Public Relations Division  
Mitsubishi Electric Corporation  
[prd.gnews@nk.MitsubishiElectric.co.jp](mailto:prd.gnews@nk.MitsubishiElectric.co.jp)  
[www.MitsubishiElectric.com/news/](http://www.MitsubishiElectric.com/news/)

## **Mitsubishi Electric Develops World's First Metal Corrosion Sensor Designed for Mounting on Printed Circuit Boards**

*Detects metal corrosion caused by exposure to the atmosphere, helping prevent equipment failure*

**TOKYO, September 4, 2019** – [Mitsubishi Electric Corporation](http://www.mitsubishielectric.com) (TOKYO: 6503) announced today that it has developed what is believed to be the world's first\* compact metal corrosion sensor small enough to be mounted on printed circuit boards. The new sensor utilizes metal corrosion monitoring technology developed by Mitsubishi Electric that detects the degree of corrosion of metal components caused by corrosive gases such as sulfur compounds in the atmosphere. The deployment of multiple sensors with different levels of corrosion resistance allows the degree of corrosion to be detected in stages, helping to prevent equipment failure. Mitsubishi Electric plans to deploy the new technology across its own industrial equipment portfolio.

\* According to Mitsubishi Electric research as of September 4, 2019

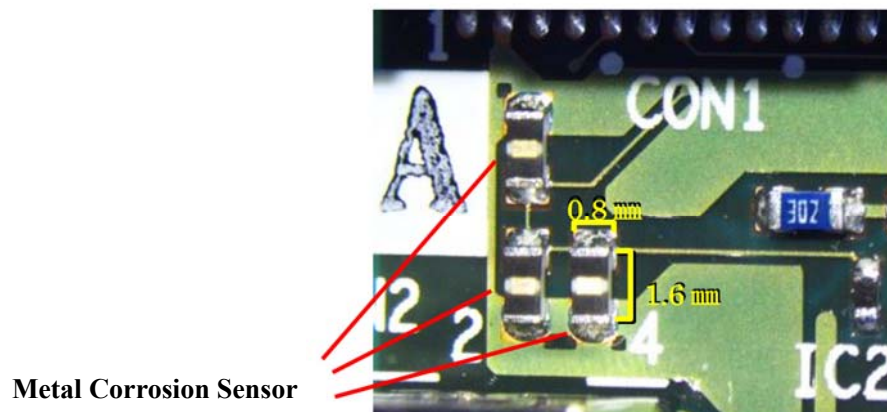

Fig. 1 Example deployment of new sensor

**Key Features**

**1) World’s first compact metal corrosion sensor that can be mounted directly on printed circuit boards**

- Its simple structure, incorporating a thin metal film and resistors and measuring just 1.6mm x 0.8mm, enables the sensor to be mounted directly on printed circuit boards and easily deployable across a wide range of products containing these, such as industrial equipment; this is believed to be a world-first.
- Detection under conditions more closely matching the environment inside the equipment eliminates the need to install additional measuring instruments such as external sensors.

**2) The degree of corrosion can be detected in stages (Fig. 2)**

- The progress of any corrosion can be gauged by measuring the increase in electrical resistance of the corrosion sensors.
- The resistance of the corrosion sensors can be adjusted by changing the composition and thickness of their metal content.
- The deployment of multiple sensors with different levels of corrosion resistance allows the degree of corrosion to be detected in stages, helping to prevent equipment failure.

When metals are exposed to corrosive gases in the atmosphere, corrosion progresses from the surface to the inside and turns into rust. Since the electrical resistance of rust is tens of thousands of times higher than that of metal, the progress of any corrosion can be gauged by measuring the increase in electrical resistance.

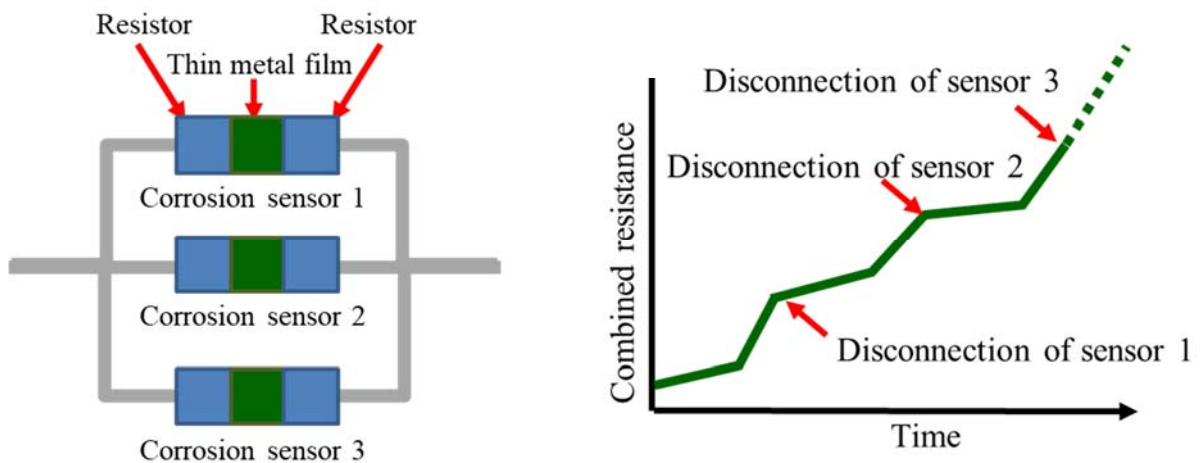

Fig. 2 Configuration of corrosion sensors (left) and resistance values detected by them (right)

**Core Specifications**

Configuration of corrosion sensor	<ul style="list-style-type: none"> <li>- Composed of a thin metal film and resistors</li> <li>- High sensitivity achieved by serially connecting resistors to a thin metal film which acts as a conductor</li> </ul>
Dimensions (W×D)	1.6mm x 0.8mm – the size does not vary regardless of the material or thickness of the metal film or the resistance level of the resistor

### **Background**

In industrial plants, quantitative analysis of color change or of rust in metal components is performed to determine their susceptibility to corrosion. In emerging countries where air pollution is often an issue, there is growing demand for proactive countermeasures to prevent equipment failures through the monitoring of the progress of metal corrosion. However, it is difficult to accurately monitor the corrosive environments inside equipment housings since conventional diagnostic technologies use external sensors to measure corrosive gases in the atmosphere.

### **Patents**

Pending patents for the technology announced in this news release number one in Japan and one outside of Japan.

###

### **About Mitsubishi Electric Corporation**

With nearly 100 years of experience in providing reliable, high-quality products, Mitsubishi Electric Corporation (TOKYO: 6503) is a recognized world leader in the manufacture, marketing and sales of electrical and electronic equipment used in information processing and communications, space development and satellite communications, consumer electronics, industrial technology, energy, transportation and building equipment. Embracing the spirit of its corporate statement, Changes for the Better, and its environmental statement, Eco Changes, Mitsubishi Electric endeavors to be a global, leading green company, enriching society with technology. The company recorded a revenue of 4,519.9 billion yen (US\$ 40.7 billion\*) in the fiscal year ended March 31, 2019. For more information visit:

[www.MitsubishiElectric.com](http://www.MitsubishiElectric.com)

\*At an exchange rate of 111 yen to the US dollar, the rate given by the Tokyo Foreign Exchange Market on March 31, 2019